

QUADRON®185Power Größe 1-2-3

NH-Sicherungs-Lasttrennleiste mit V-Klemmenanschluss
 NH in-line fuse switch-disconnector with V terminal connection
 Seccionadores verticales para fusibles NH con conexión a V
 réglette interrupteur-sectionneur-fusibles DIN avec bornes à V
 base sezion. verticale per fusibili NH con morsetti a V
 NH-条形熔断器式负荷隔离开关 带V型端子连接

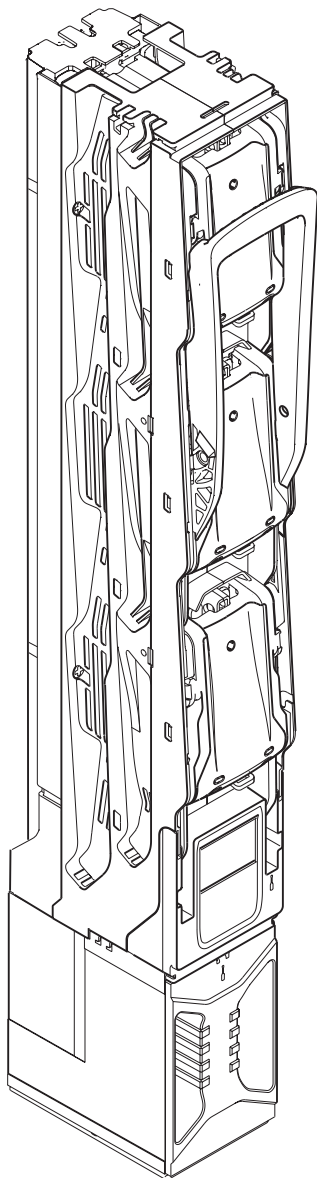

Achtung: Vor Installations- oder Servicearbeiten Stromversorgung unterbrechen, um Unfälle zu vermeiden. Die Geräte müssen in einem passenden Gehäuse eingebaut und gegen Verschmutzung geschützt werden. Inbetriebsetzung und Wartung nur durch Fachpersonal!

Attention: To prevent electrical shock, disconnect from power source before installing or servicing. Install in suitable enclosure. Keep free from contaminants. To be commissioned and maintained only by qualified personnel!

Atención: Con el objeto de evitar accidentes, hay que desconectar la alimentación eléctrica antes de realizar el montaje y la puesta en marcha. Debe instalarse en una caja o armario apropiado. Debe protegerse el producto de los ambientes agresivos. La puesta en marcha y el mantenimiento ha de hacerlo exclusivamente por personal especializado!

Attention: Avant le montage et la mise en service, couper l'alimentation secteur afin d'éviter tout accident. Prévoir une mise en coffret ou armoire appropriée, protéger le produit contre les environnements agressifs. Mise en service en entretien: seulement par du personnel spécialisé!

Attenzione: Per prevenire infortuni, togliere tensione prima dell'installazione o manutenzione. Installare in custodia idonea. Tenere lontano da contaminanti. Messa in servizio e manutenzione solo da personale specializzato!

注意: 安装前或检修前应切断电源, 以防事故。开关应安装在适合的箱体内, 同时应做好防污染保护。只有专业人员才能做运行、维护、保养的工作。

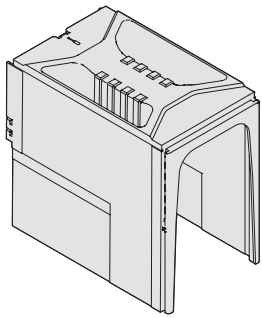

33733



33156

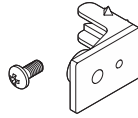

33113



33758

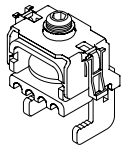

33738

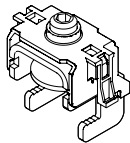

33740

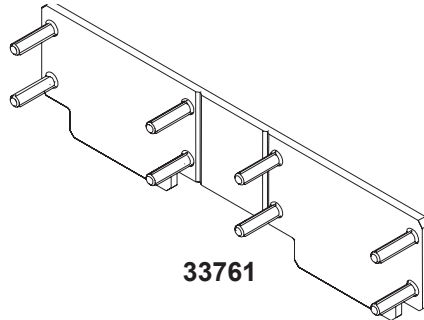

33761

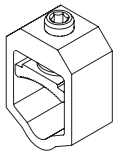

33558
33559

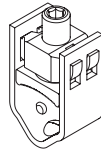

33561
33562

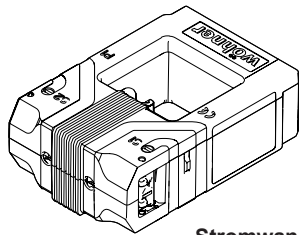

Stromwandler / current transformers
siehe Internet / see on
www.woehner.de

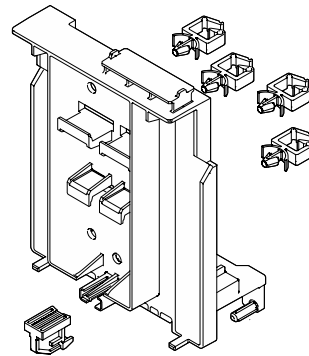

33769

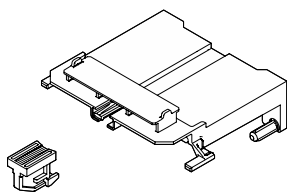

33768

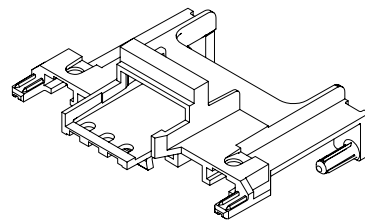

1. Schienensystem

Busbar system

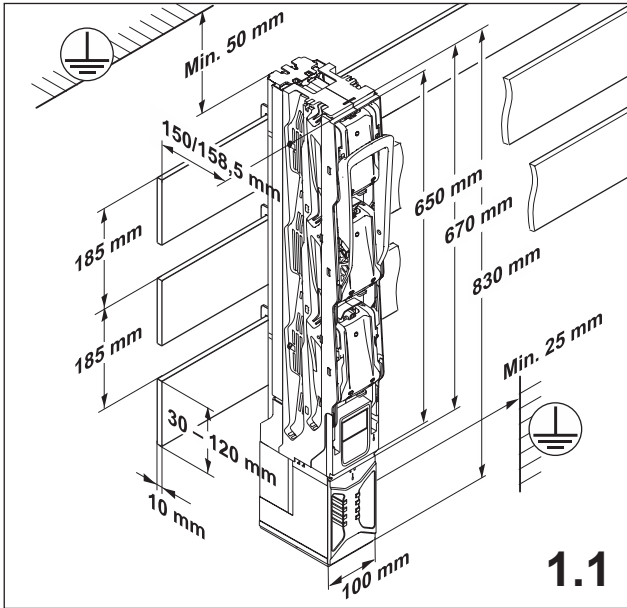

1.1

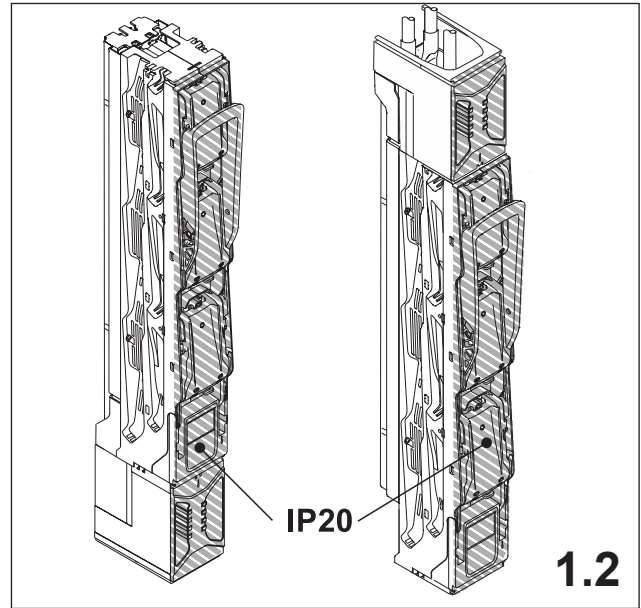

1.2

2. Montage QUADRON®185Power

Assembly

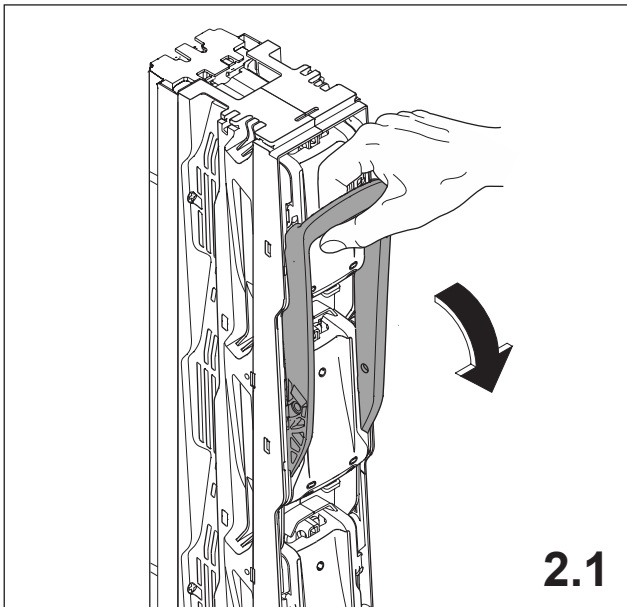

2.1

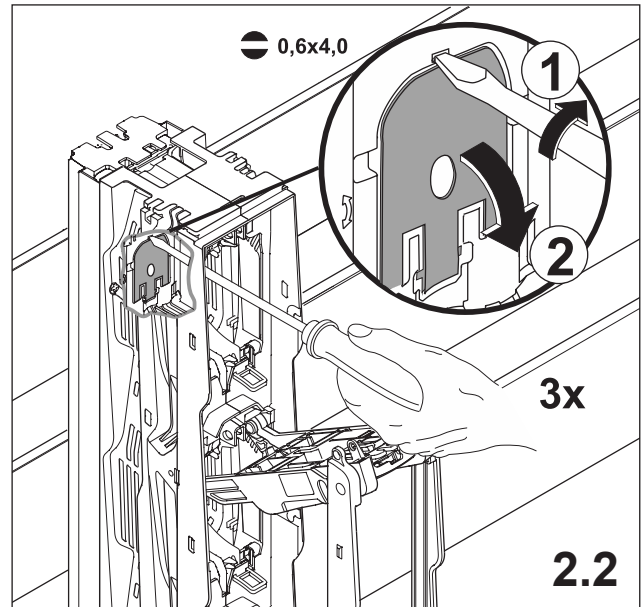

2.2

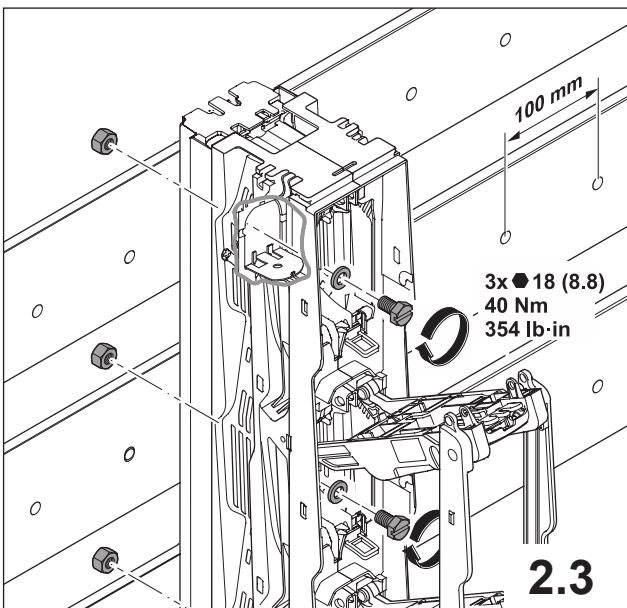

2.3

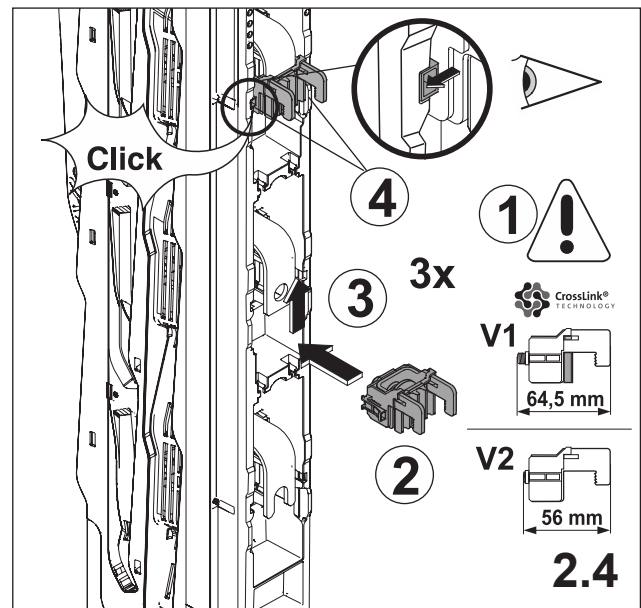

2.4

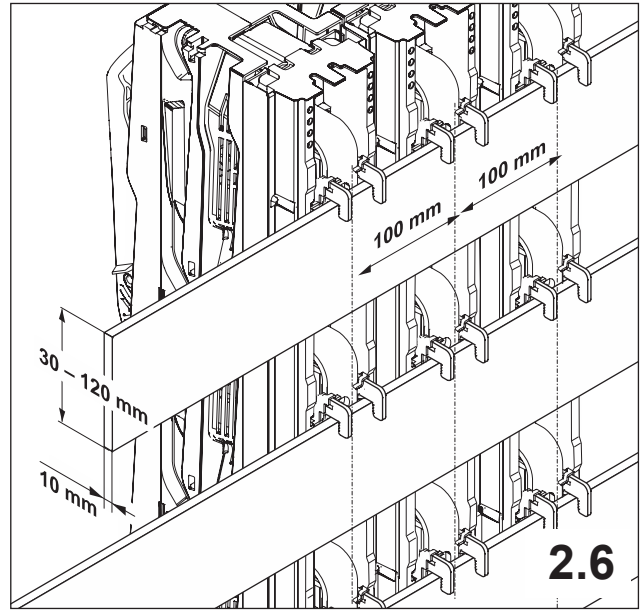
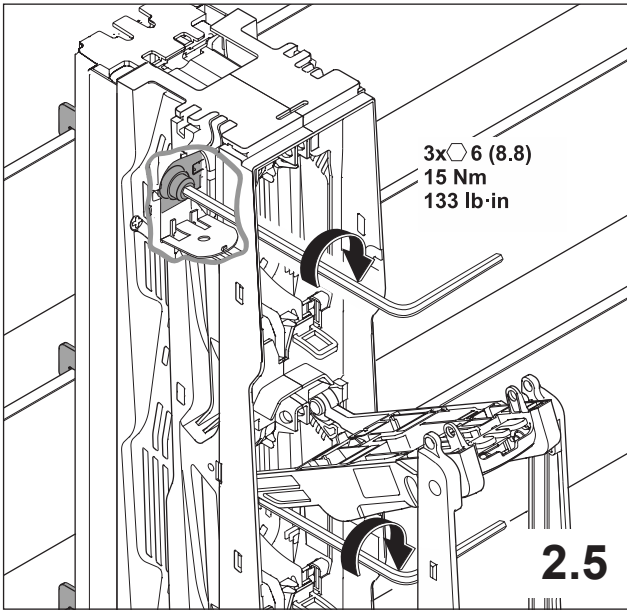

3. Anschlüsse

Connections

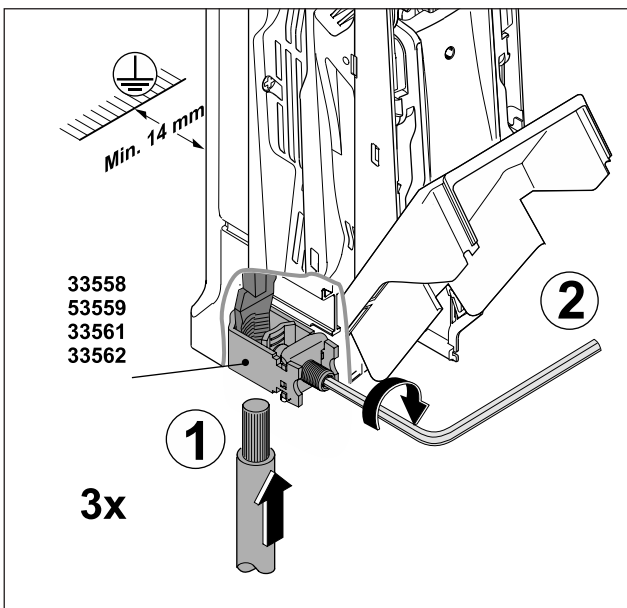
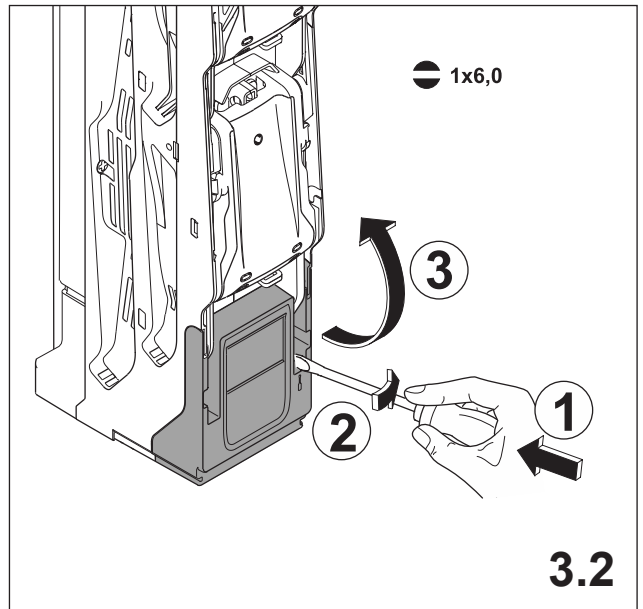
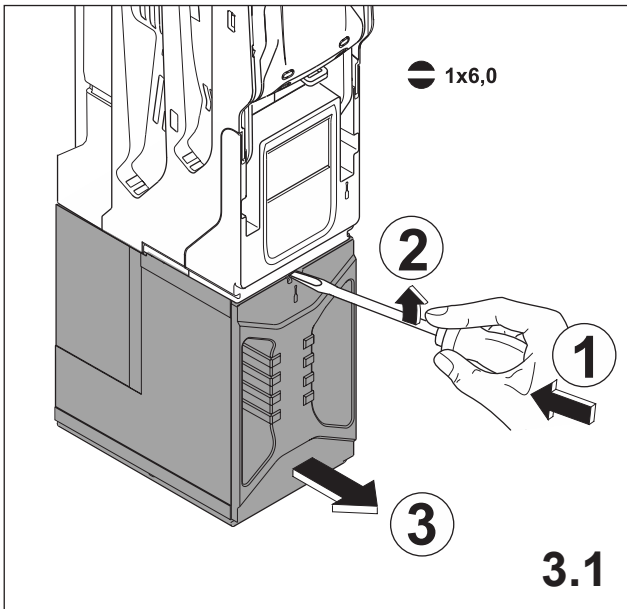

33558	33559	33561	33562
3x 6			
27-30 Nm	36-40 Nm	27-30 Nm	
239-265 lb-in	319-354 lb-in	239-265 lb-in	

4. Anschlüsse oben

Connection up

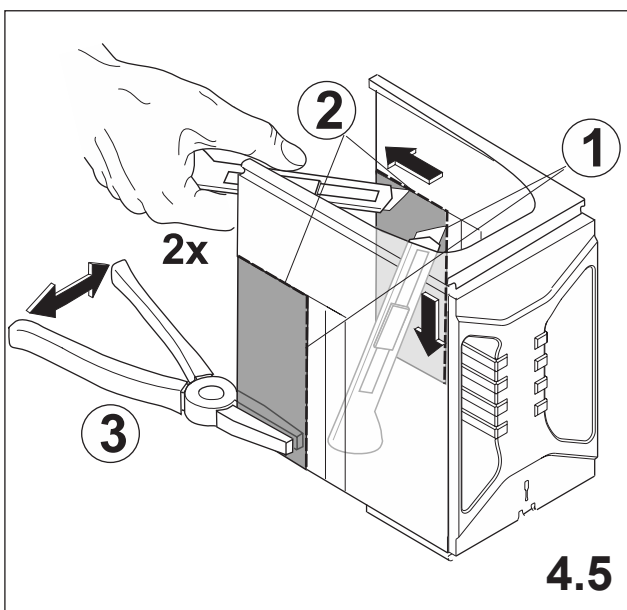
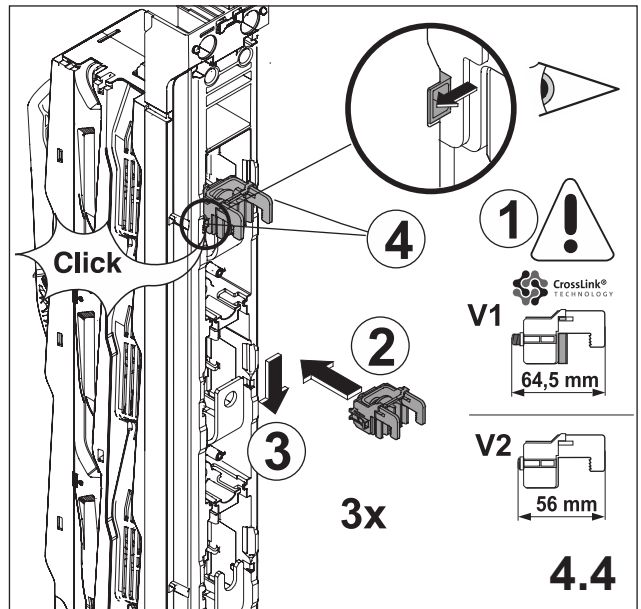
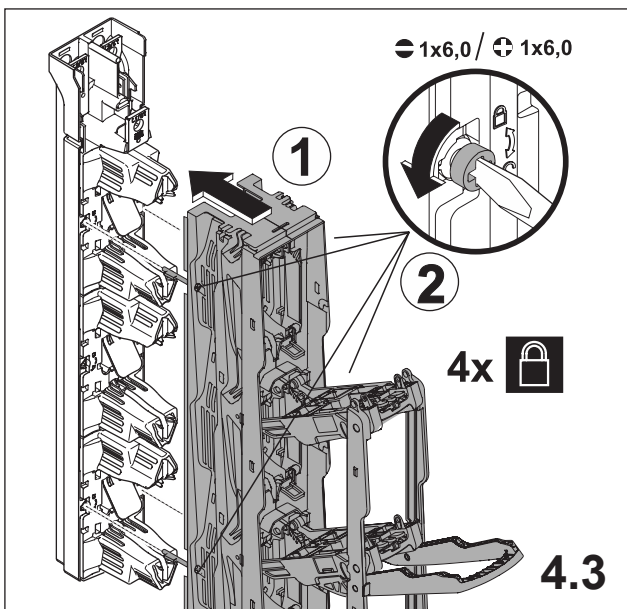
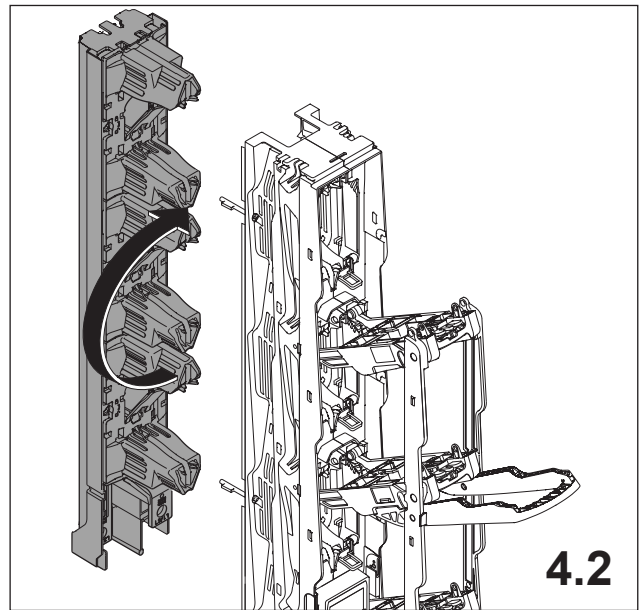
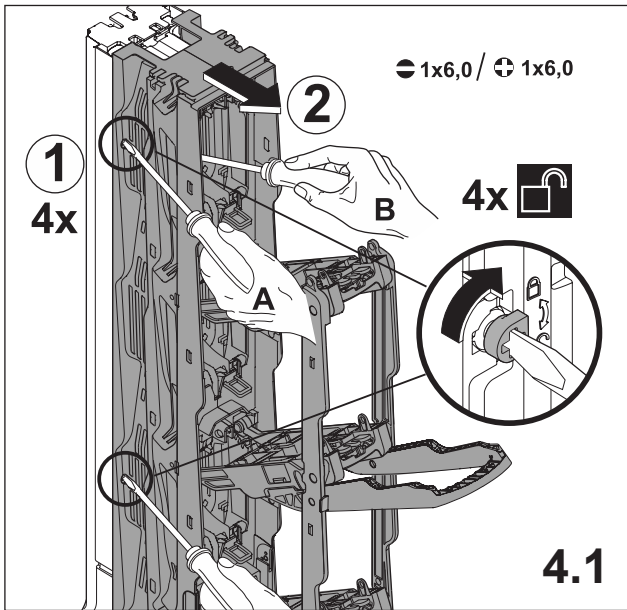

5. Abdeckung immer verwenden Always use the cover

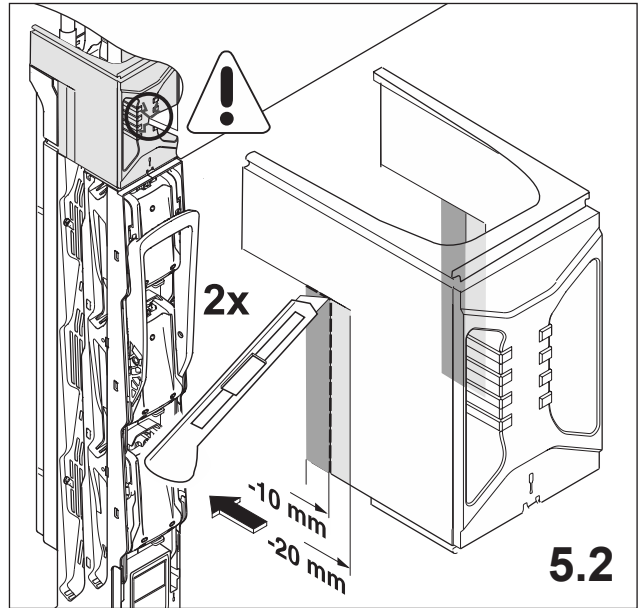
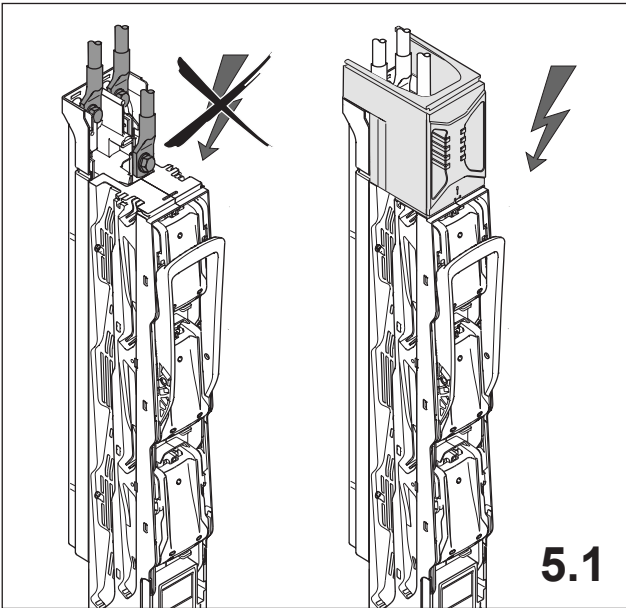

6. Sicherungen auswechseln Change the fuses

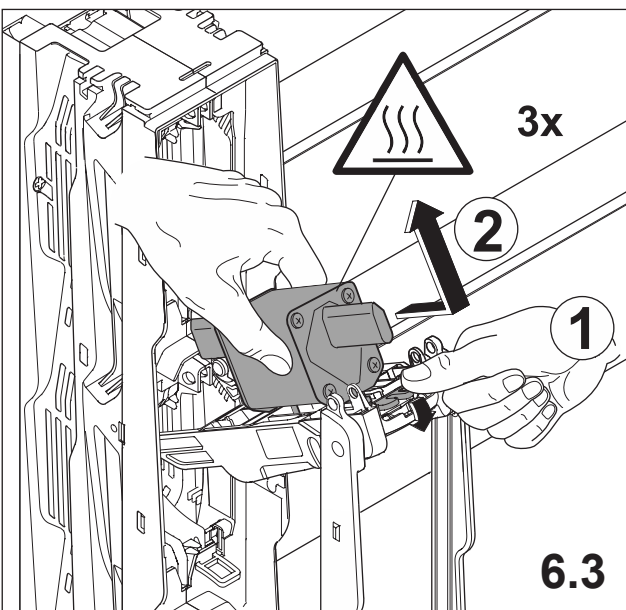
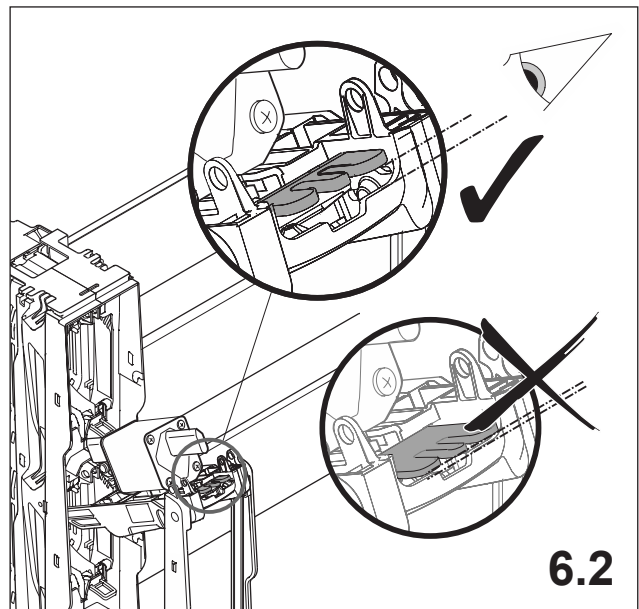
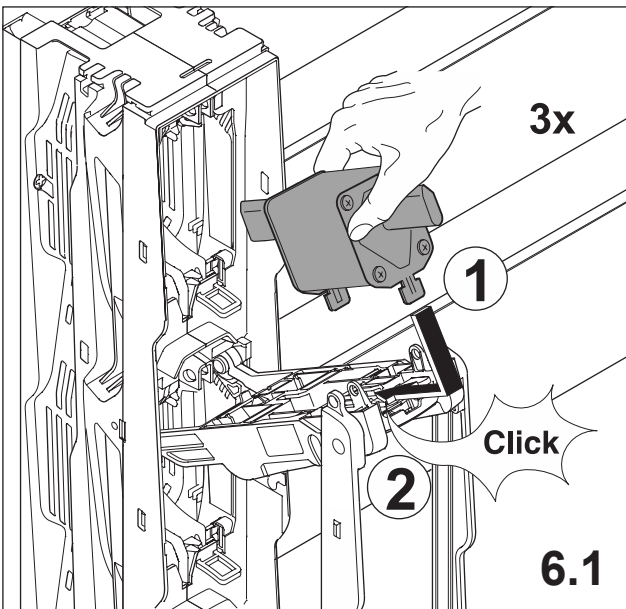

7. Abschließbarkeit 3-polig Looking the fuse holder three-pole

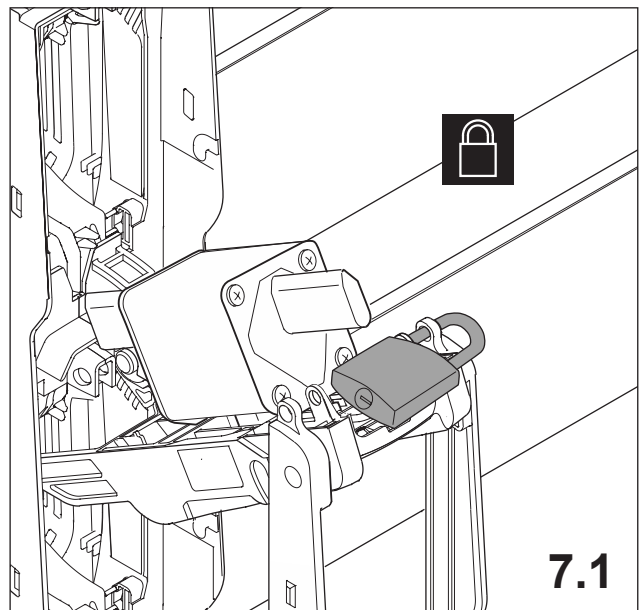

8. Abschließbarkeit 1-polig Looking the fuse holder single-pole

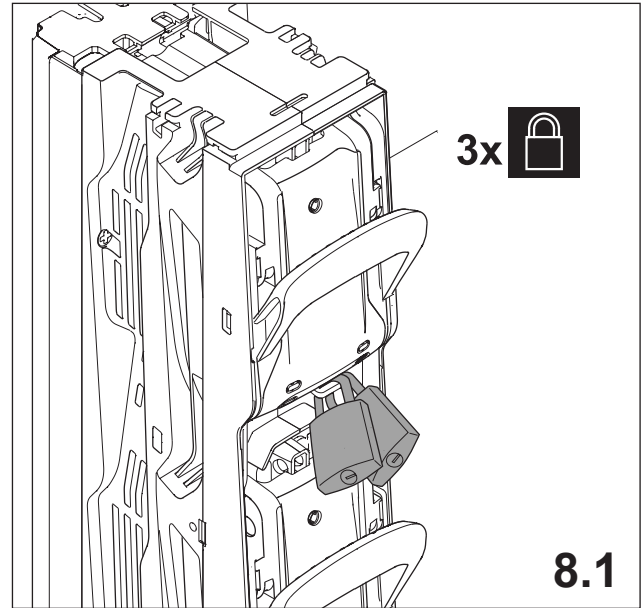
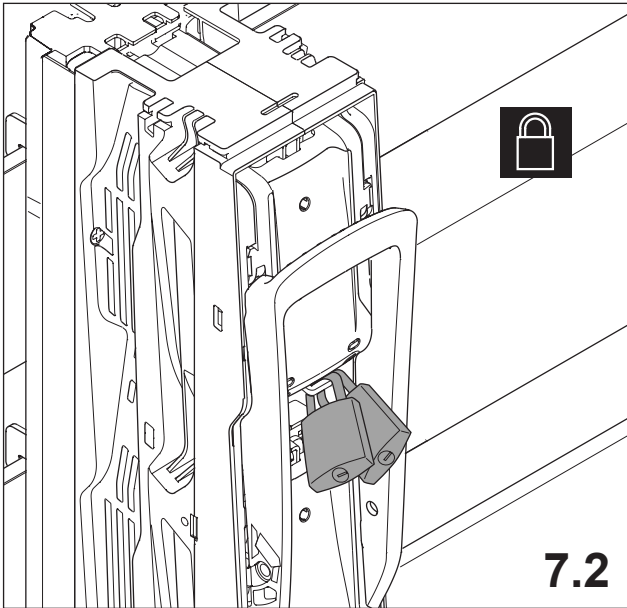

9. Plombieren der NH-Leiste Sealing of fuse holder

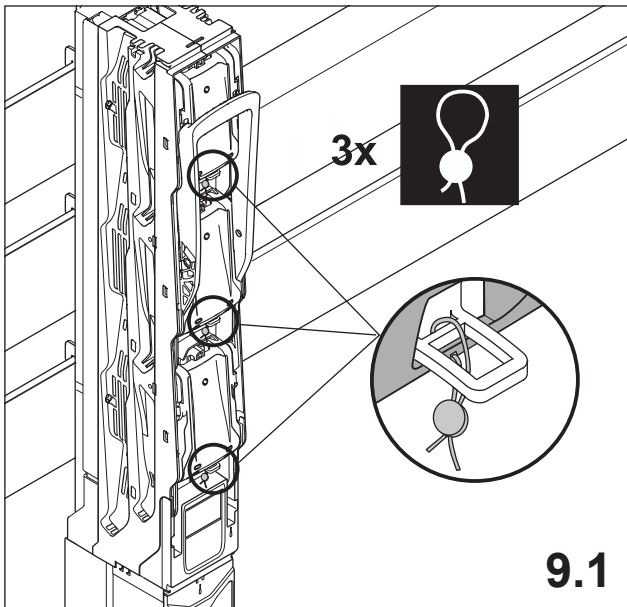

10. Parkposition 1-polige NH-Leiste Parking position single-pole

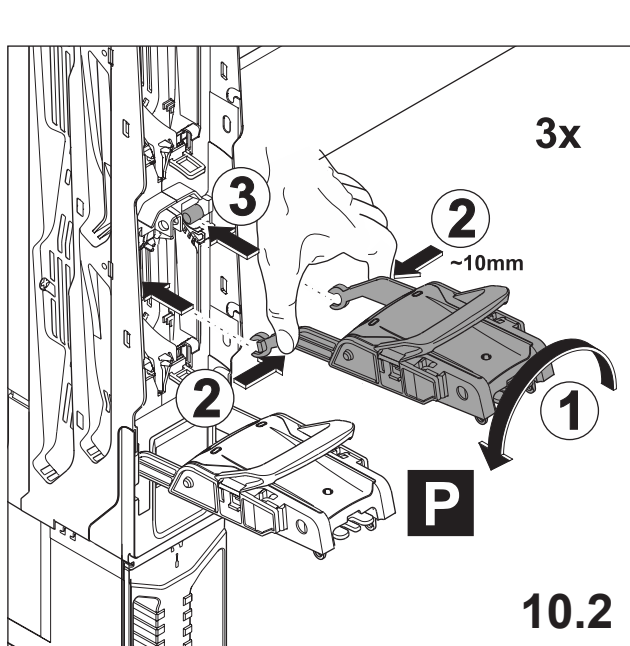
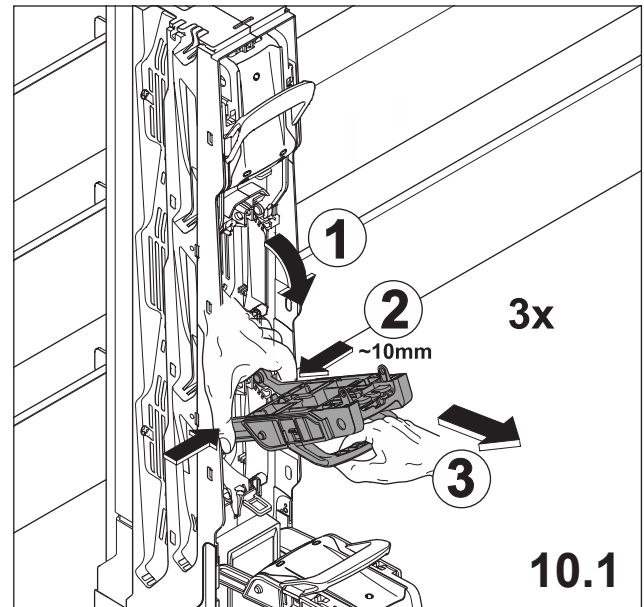

11. Spannungsprüfung Voltage test

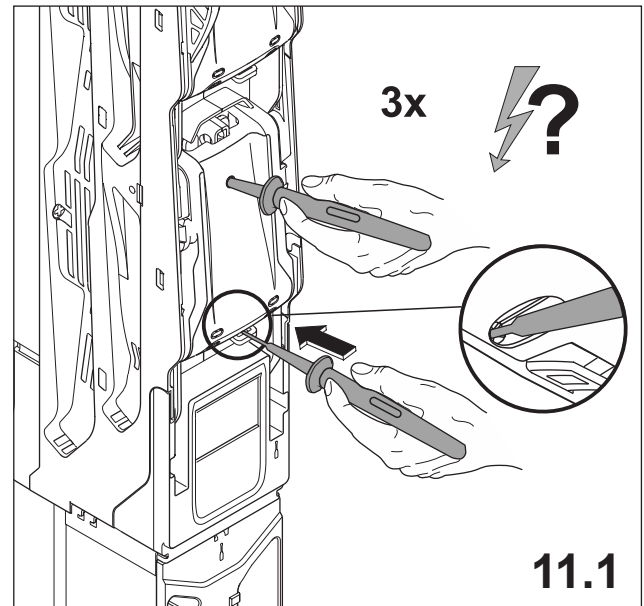

12. Zubehör - Stromwandler - Montage, Einbau und Kabelverlegung

Accessories - Current transformer - assembly and cable routing

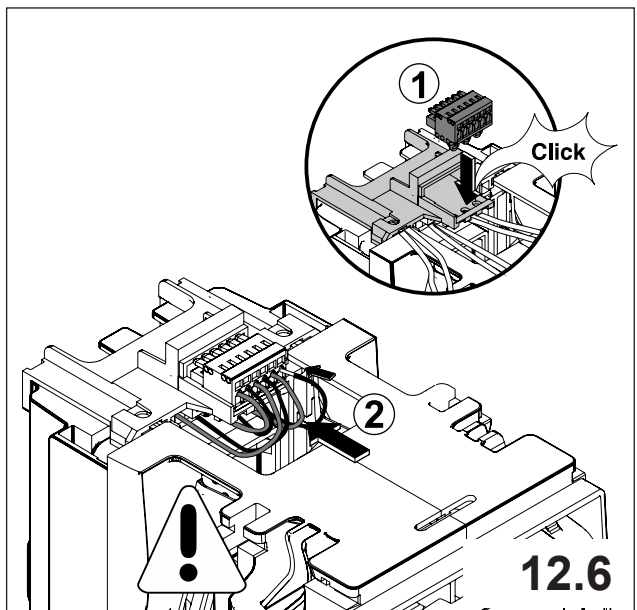
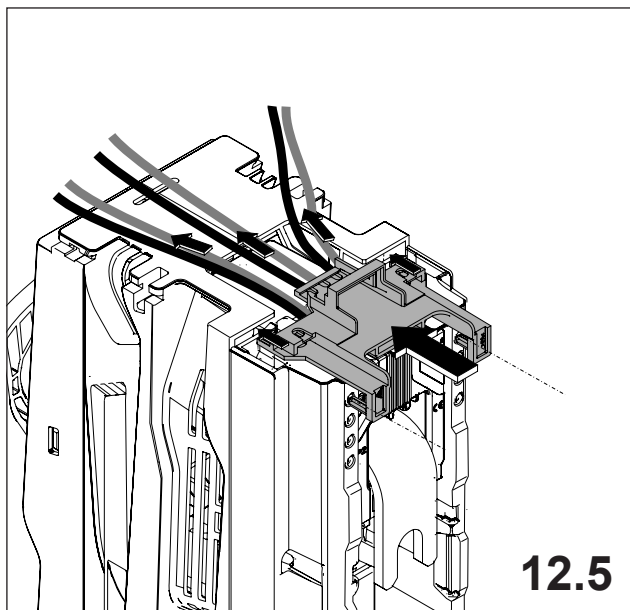
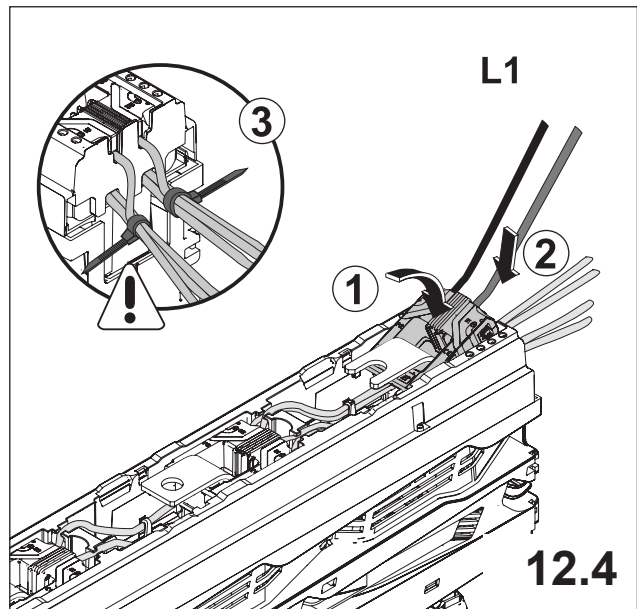
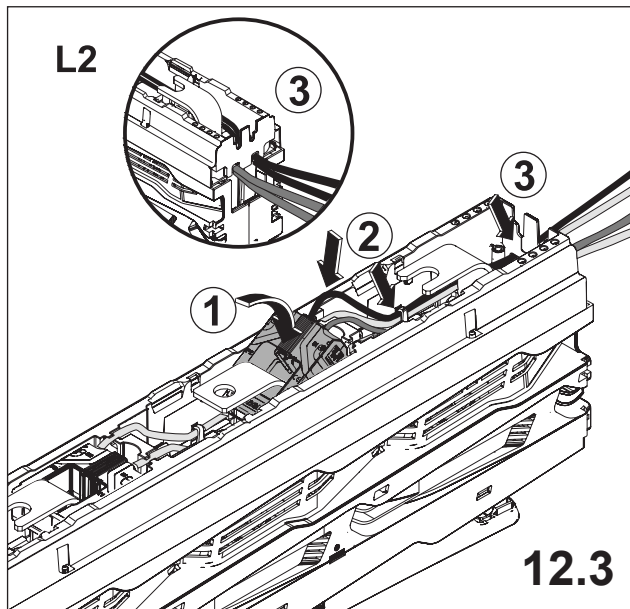
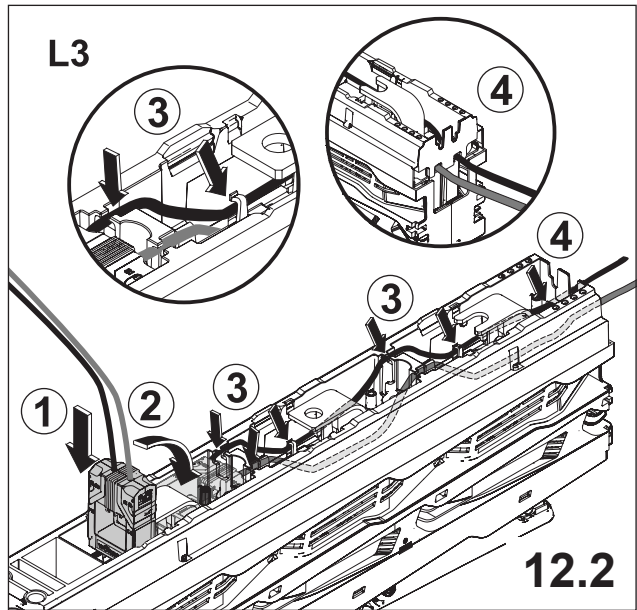
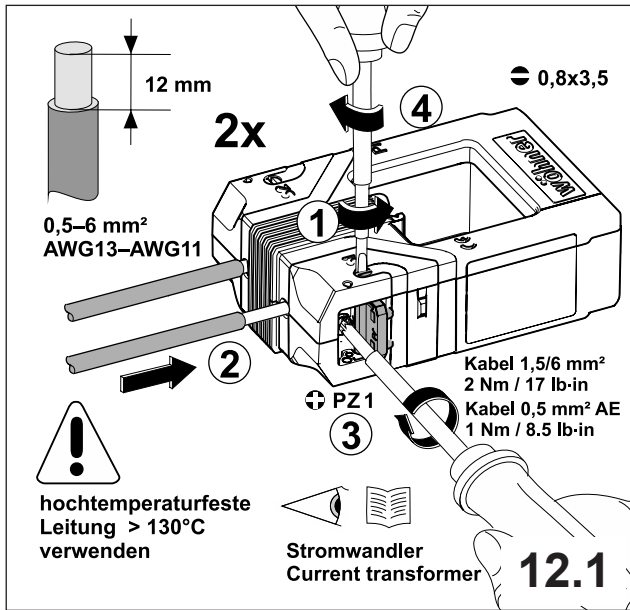

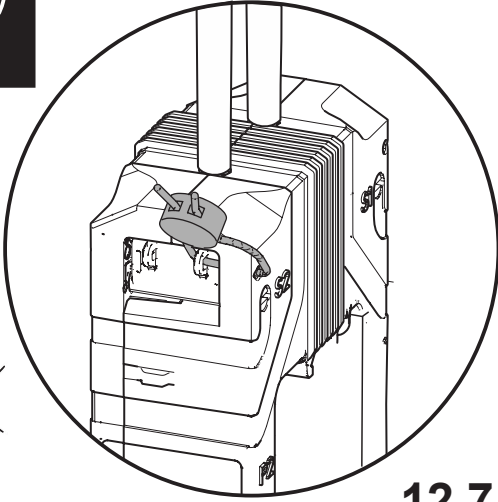

12.7

13. A Meldeschalter - Einbau und Kabelverlegung innen

Pilot switch - assembly and cable routing inside

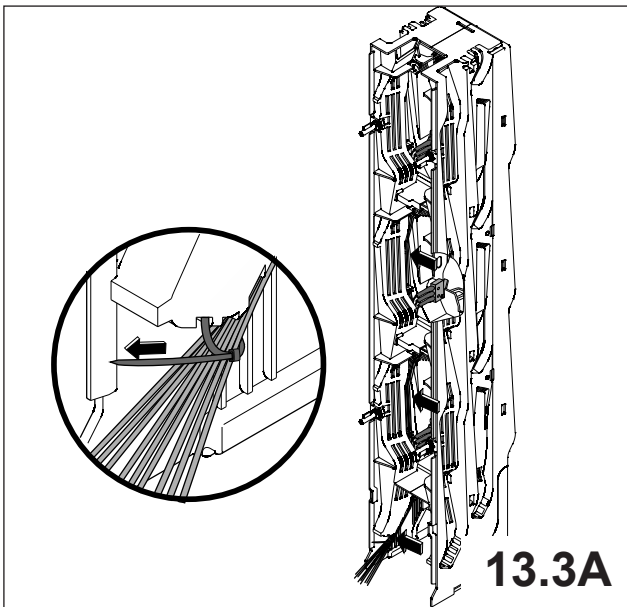
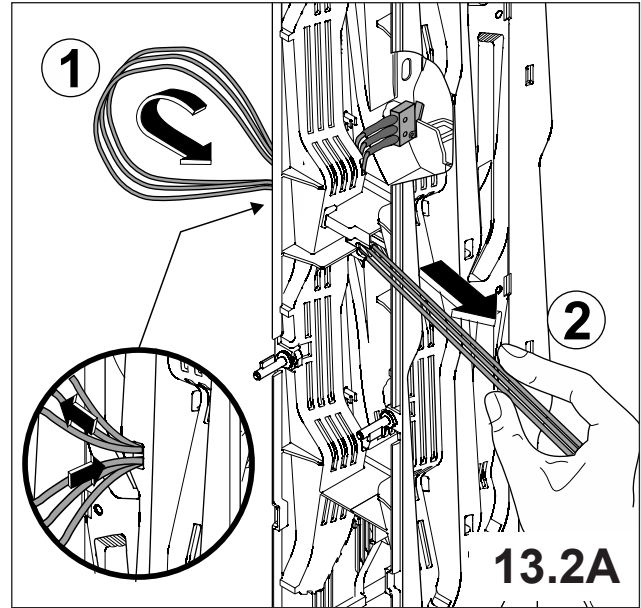
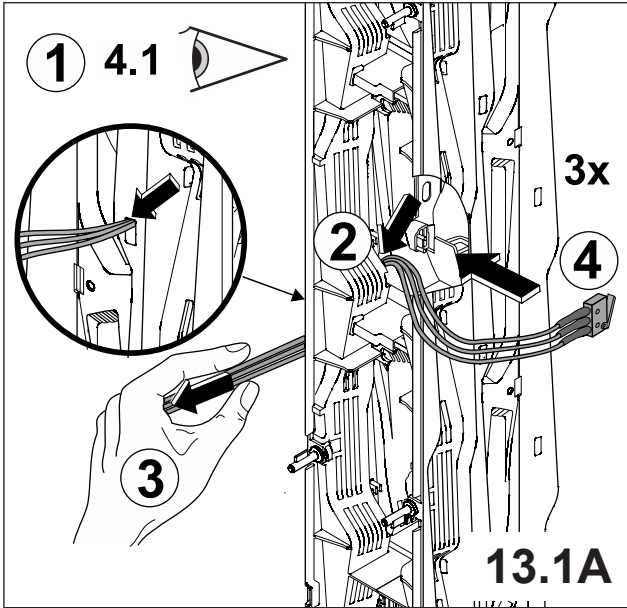

13. B Meldeschalter - Einbau und Kabelverlegung außen

Pilot switch - assembly and cable routing outside

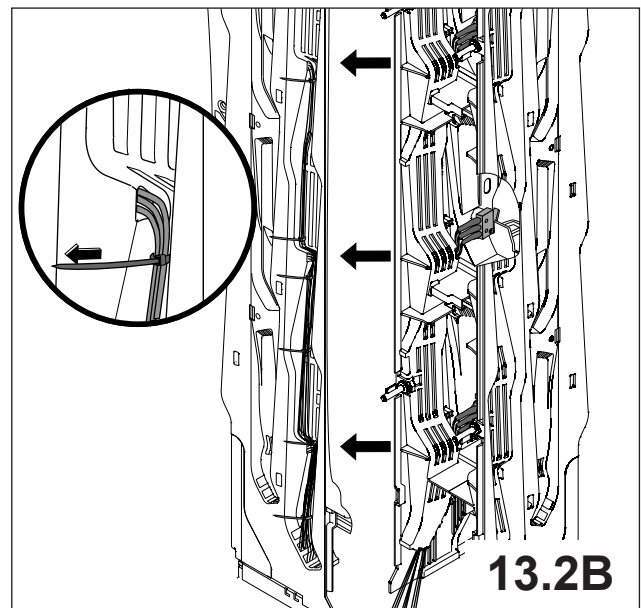
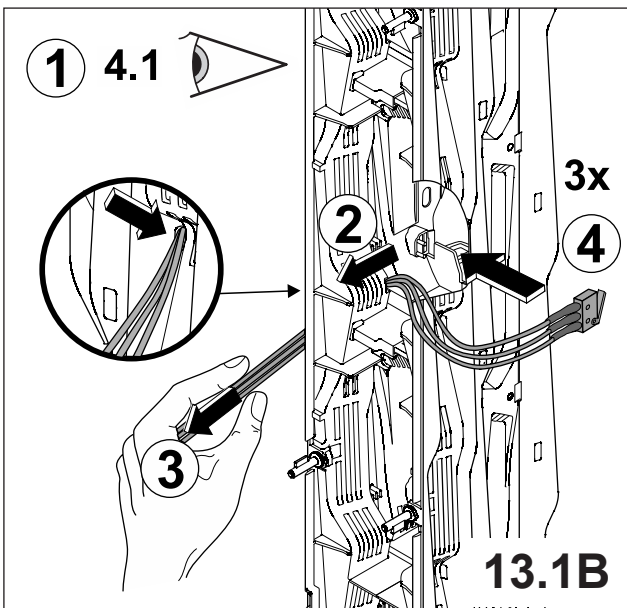

14. Berührungsschutz montieren

assembly touch guard

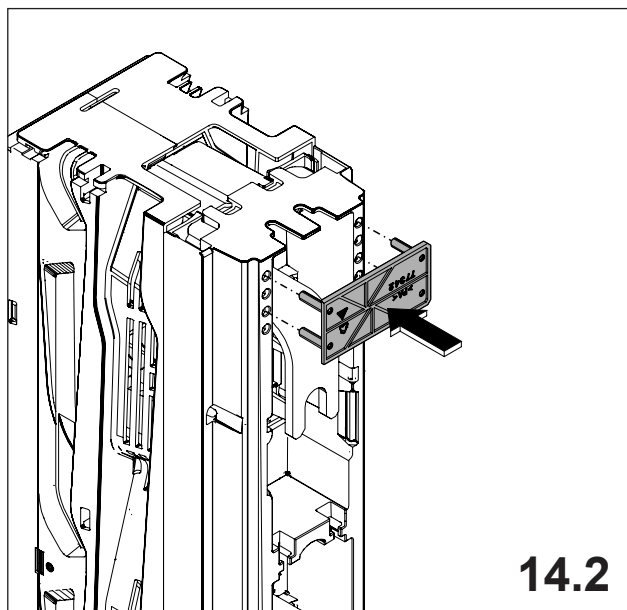
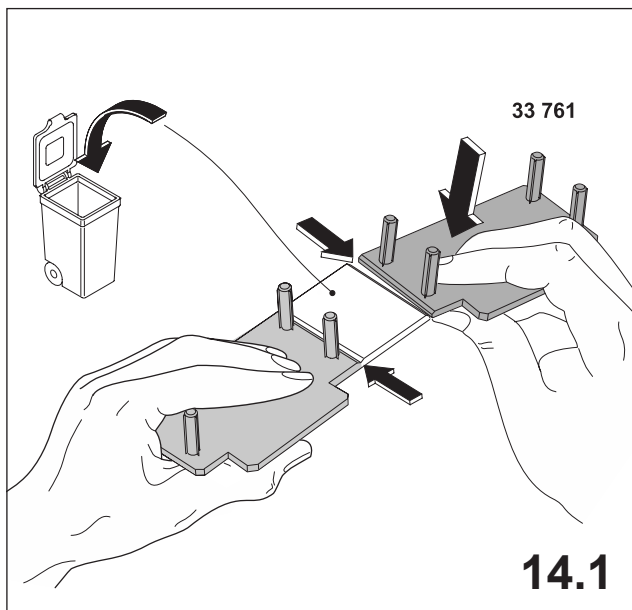

Notizen

A large grid of small dots for taking notes, consisting of 20 columns and 30 rows.