

Secur PowerLiner

D0-Reiter-Lasttrennschalter mit Sicherungen
 D0 busbar mounted switch-disconnector
 D0 interruptor-seccionador con fusibles
 sezionatore per fusibili D0
 D0 隔离开关熔断器组

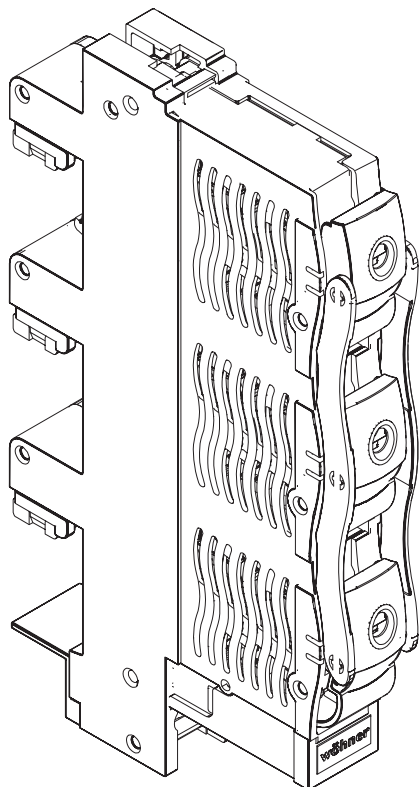

Achtung: Vor Installations- oder Servicearbeiten ist die Stromversorgung grundsätzlich zu unterbrechen. Arbeiten unter Spannung sind gesondert, unter Berücksichtigung der gültigen, landesspezifischen Gesetze, Vorschriften und Normen und dem gegebenen Arbeitsumfeld einzeln zu bewerten. Die Geräte müssen in einem passenden Gehäuse eingebaut und gegen Verschmutzung geschützt werden. Inbetriebsetzung und Wartung nur durch Fachpersonal!

Attention: To prevent electrical shock, disconnect from power source generally before installing or serving. Working under voltage has to be assessed separately in compliance with the consideration of current country-specific laws, regulations and standards and the working environment. Install in suitable enclosure. Keep free from contaminants. To be commissioned and maintained only by qualified personnel!

Atención: Para prevenir descargas eléctricas, desconecte la fuente de alimentación general antes de instalar o manipular. Trabajar bajo tensión eléctrica debe ser evaluado por separado de acuerdo con las leyes, reglamentos y normas específicas de cada país así como el entorno de trabajo. Debe instalarse en una caja o armario apropiado. Debe protegerse el producto de los ambientes agresivos. La puesta en marcha y el mantenimiento ha de hacerlo exclusivamente por personal especializado!

Attention: Afin d'éviter les chocs électriques, déconnecter la source avant installation ou manipulation. Travailler sous tension doit être considéré conformément aux réglementations et aux normes spécifiques en vigueur dans le pays, ainsi qu'aux conditions particulières de l'environnement du poste de travail. Prévoir une mise en coffret ou armoire appropriée, protéger le produit contre les environnements agressifs. Mise en service en entretien: seulement par du personnel spécialisé!

Attenzione: Non eseguire mai interventi con tensione inserita! Interventi speciali con tensione inserita potranno essere eseguiti soltanto rispettando le norme e leggi nazionali in vigore e valutando il relativo ambiente di lavoro. Installare in custodia idonea. Tenere lontano da contaminanti. Messa in servizio e manutenzione solo da personale specializzato!

注意: 安装前或检修前, 务必要先切断电源, 以防事故。

请注意! 为防止触电, 进行安装或检修前, 务必要先切断电源。如果进行带电工作, 要根据本国的特定法律、要求、规定、标准及工作环境单独考虑。

Zubehör accessoires

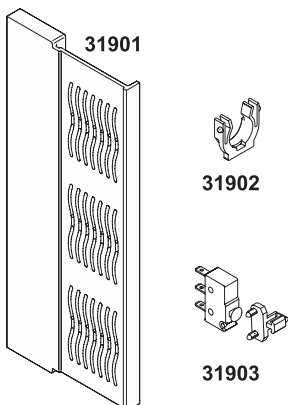

1. Schienensystem busbar system

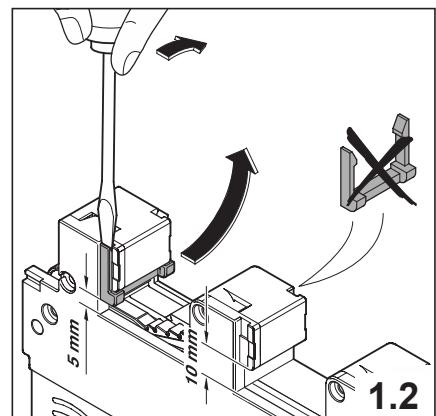
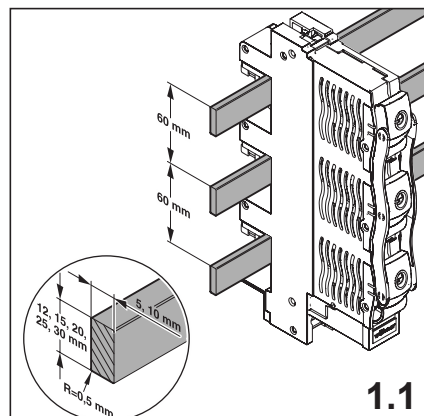

ALLES MIT SPANNUNG

**2. Montage PowerLiner
assembly of the PowerLiner**

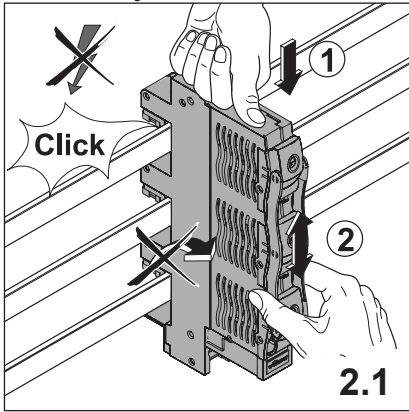

3. Einsetzen der Sicherung insert of the fuse

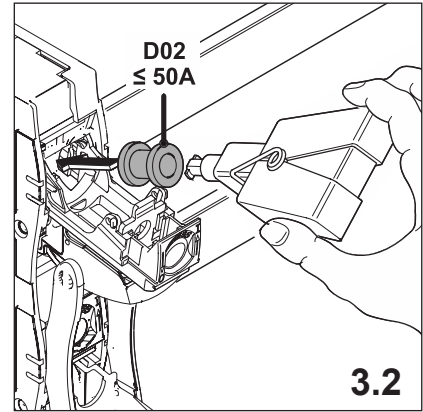
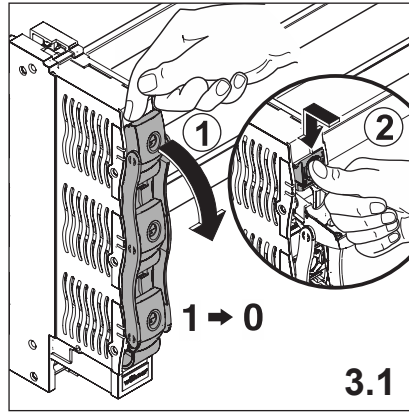

**Reduziereinsatz für Sicherungen D01
reducing Set for D01-Fuses**

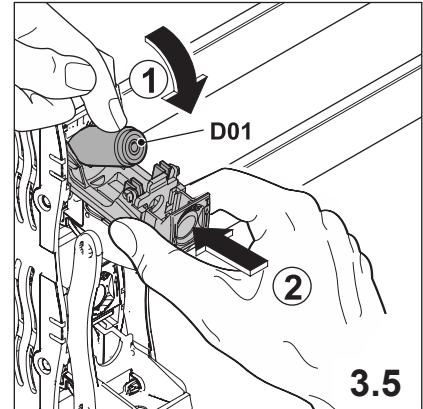
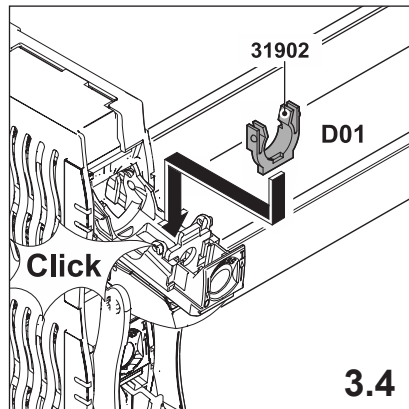
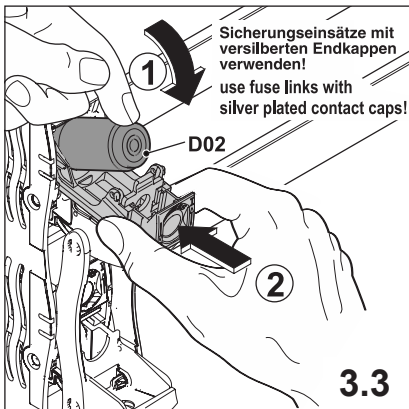

**4. Demontage PowerLiner
disassembly of the PowerLiner**

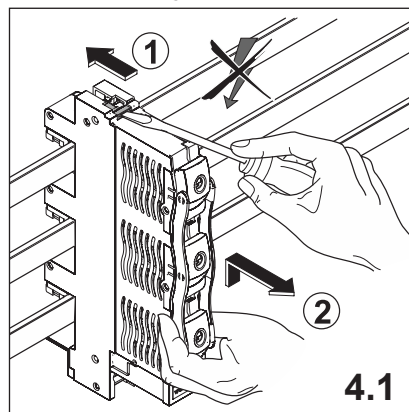
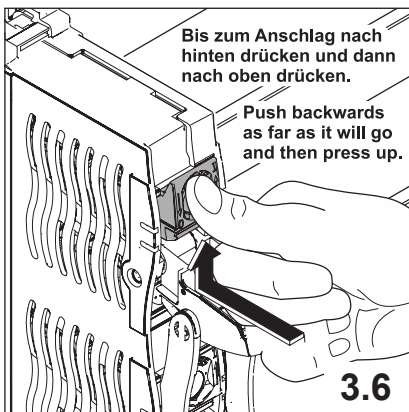

**5. Zubehör Montage
assembly of accessories**

